

SPECIFICATIONS

GENERAL:

The FoodSafe Floor Clean Out is a stainless steel system that allows easy access to clear clogs and debris in underground drain lines. When not in use, it keeps your system secure - air & water tight.

MATERIALS:

- T304 or T316 Stainless Steel
- EPDM

INSTALLATION:

The FoodSafe Floor Clean Out shall be installed in accordance with the manufacturers installation instructions and recommendations.

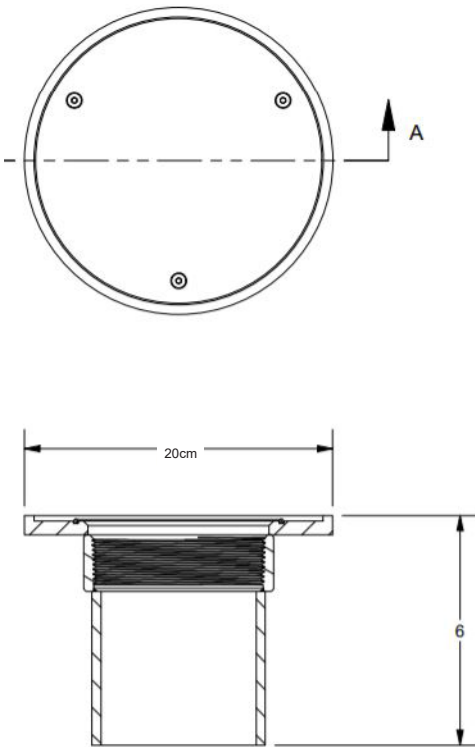

SECTION A-A

TYPICAL PROFILE OF A FOODSAFE FLOOR CLEAN OUT

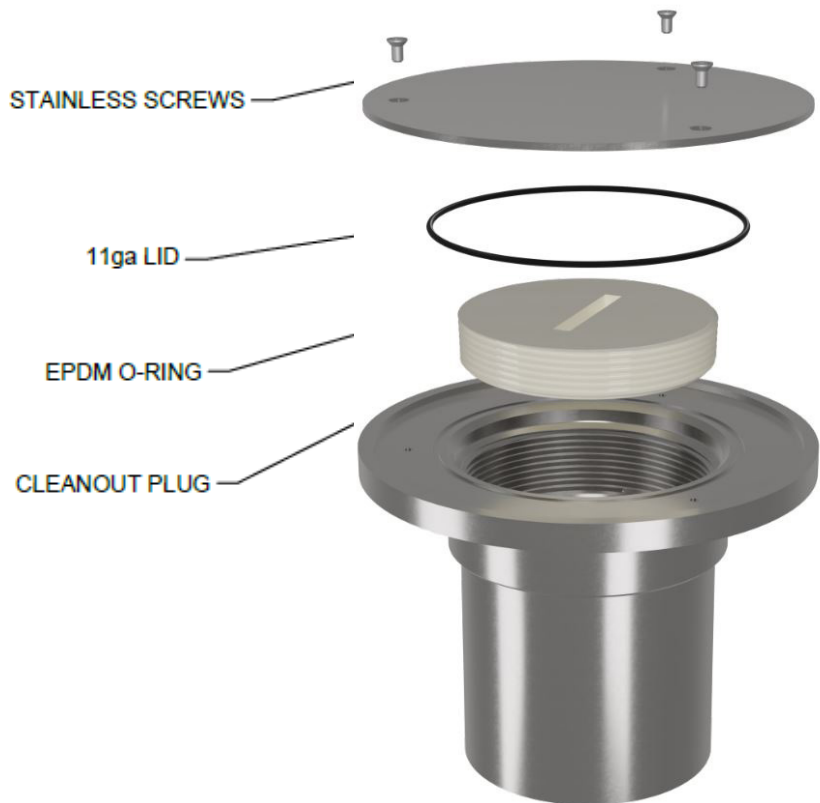

MEASUREMENTS

DESCRIPTION	PART NO.	PIPE SCHEDULE (CM)	A (CM)	B (CM)	C NOMINAL SIZE (CM)	D (CM)
FLOOR CLEAN OUT 8" TOP, 4" PIPE OUTLET	FSFCO-84A	25	20	1	10	16
FLOOR CLEAN OUT 8" TOP, 4" PIPE OUTLET	FSFCO-84	102	20	1	10	16

SPECIFYING ENGINEER IS RESPONSIBLE FOR CONCRETE ENCASEMENT AND REINFORCING BASED UPON APPLICATION AND LOCAL CODES. FOODSAFE DRAINS RESERVES THE RIGHT TO CHANGE THE PRODUCT AND SPECIFICATIONS WITHOUT NOTICE